

深圳市占開科技有限公司

ShenZhen ZhanKai Technology CO.,LTD

TEL:0769-81802125

FAX:0769-81802126

DOCUMENT NO.

RDE0184A

SERIAL NO.

A2002H02-NP

Material : Nylon 66 UL 94V-0

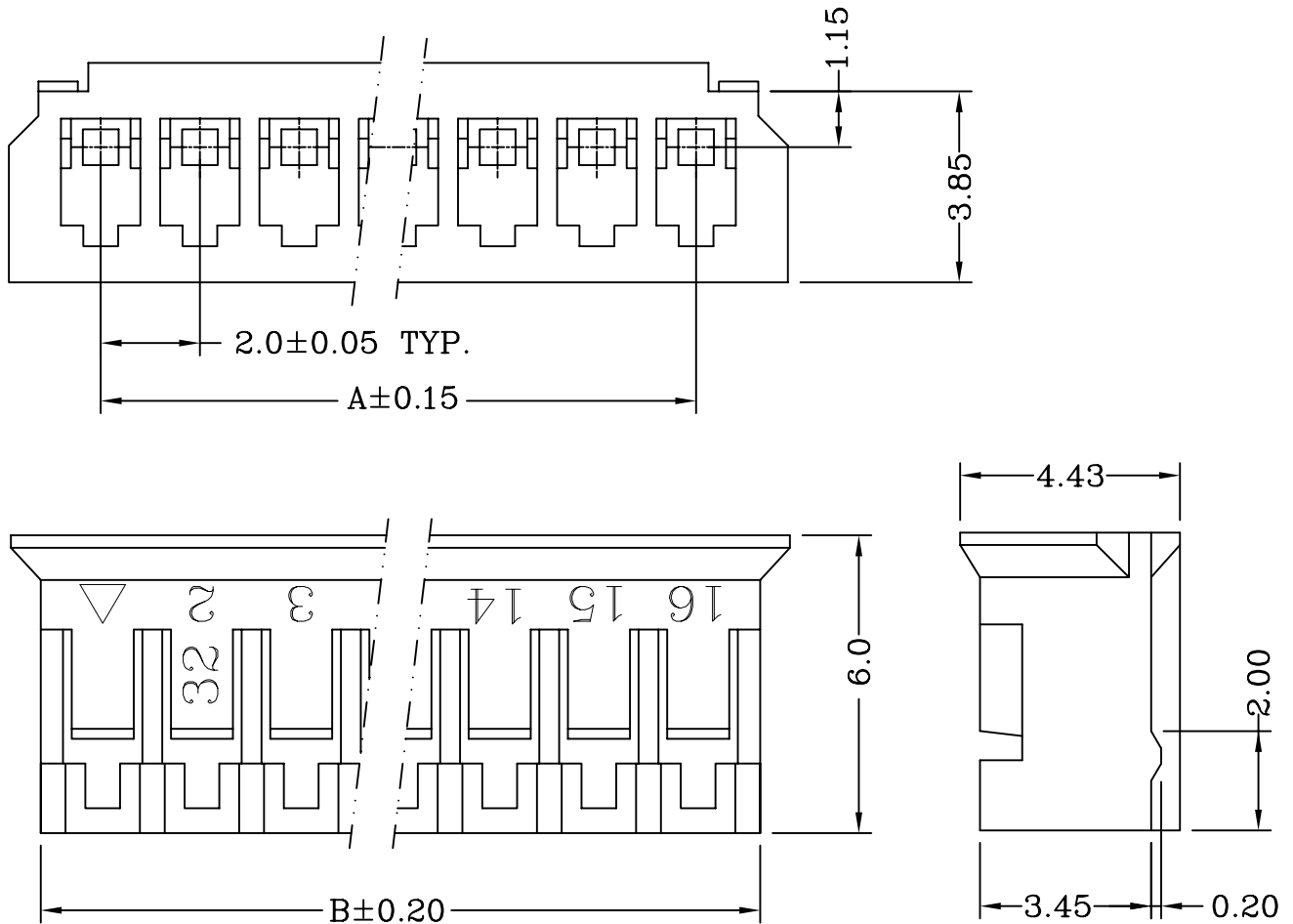

Dimensional & Ordering Information:

Circuits	Part No	Dimensions		PCS/BAG
		A	B	
2	A2002H02-2P	2.00	4.50	1000
3	A2002H02-3P	4.00	6.50	1000
4	A2002H02-4P	6.00	8.50	1000
5	A2002H02-5P	8.00	10.50	1000
6	A2002H02-6P	10.00	12.50	1000
7	A2002H02-7P	12.00	14.50	1000
8	A2002H02-8P	14.00	16.50	1000
9	A2002H02-9P	16.00	18.50	1000
10	A2002H02-10P	18.00	20.50	1000
11	A2002H02-11P	20.00	22.50	1000
12	A2002H02-12P	22.00	24.50	1000
13	A2002H02-13P	24.00	26.50	1000
14	A2002H02-14P	26.00	28.50	1000
15	A2002H02-15P	28.00	30.50	1000

REV.	ECN NO.	UNIT	TOLERANCE	PROJECTION	DRAWING	CHECK	APPROVAL
A	NEW DRAWING	mm	*** ±0.08		涂红军	—————	邹朝辉
B			** ±0.15				
			* ±0.25				

深圳市占開科技有限公司

ShenZhen ZhanKai Technology CO.,LTD

TEL:0769-81802125

FAX:0769-81802126

DOCUMENT NO.

RDE0046A

SERIAL NO.

A2002T

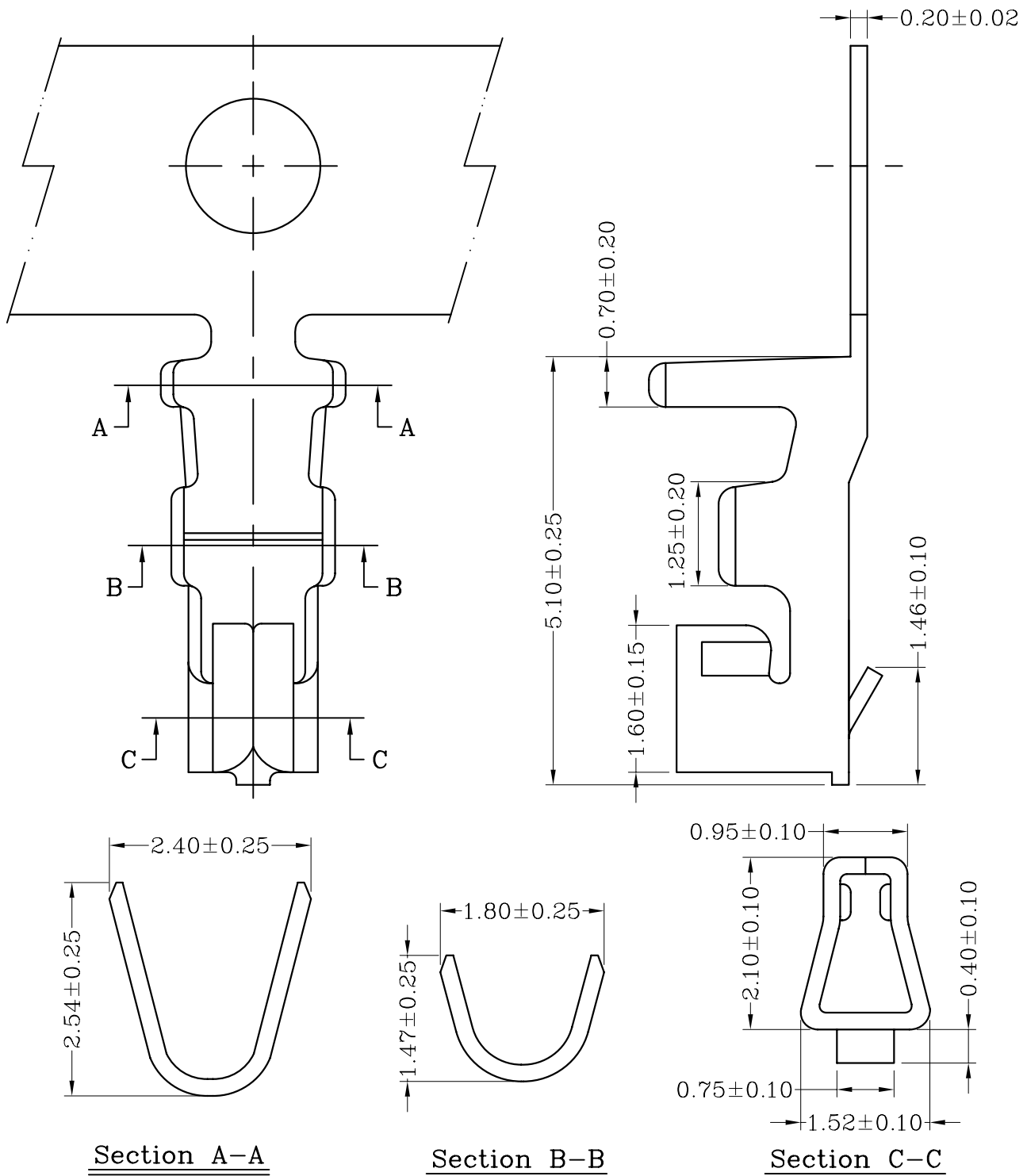

Specifications & Ordering Information:

Part No	Wire Range	Insulation O.D.	Material	Finish	Qty/reel
A2002TOP-2	AWG #24~#28	1.50mm(max)	Phosphor bronze	Tin-plated	10,000 PCS

REV.	ECN NO.	UNIT	TOLERANCE	PROJECTION	DRAWING	CHECK	APPROVAL
A	NEW DRAWING	mm	*** ± 0.08		涂红军	—	邹朝辉
B			** ± 0.15				
			* ± 0.25				